

LIST OF PRODUCTS

- * Digital Multimeter
- * AC Clamp Adaptor
- * Thermo Anemometer
- * Distance Meter
- * Network Cable Tester
- * Earth Resistance Tester
- * DC Power Supplies
- * Calibrators
- * Frequency Counter
- * Phasing Sticks
- * Waterproof Pen Testers
- * EMF Detector
- * Wood, Paper & Grain Moisture Meter
- * Transistorised Electronic Analog & Digital Insulation Resistance Testers(upto 10 KV)
- * Digital Sound Level Meter & Sound Level Calibrator
- * Digital contact & Non-contact Type Tachometer
- * Digital Non-contact (infrared) Thermometer
- * Maximum Demand Controller/Digital Power Meter
- * Digital Hand Held Temperature Indicators
- * Digital AC & AC/DC Clampmeter
- * AC/DC Current Adaptor
- * Thermo Hygrometer
- * Digital Lux Meter
- * Power Factor Regulator
- * Digital Panel Meters
- * High Voltage Detector
- * Gas Analysers
- * Function Generator
- * Battery Tester
- * Solar Power Meter



G 17, Bharat Industrial Estate, T. J. Road,
Sewree (W), Mumbai - 400 015. INDIA.

Sales Direct : (022) 24156638

Tel. : (022) 24124540, 24181649. **Fax :** (022) 24149659

Email : kusam_meco@vsnl.net

Website : www.kusamelectrical.com
www.kusam-meco.co.in



AN ISO 9001:2015 COMPANY

**AC TRUE RMS
DIGITAL CLAMPMETER WITH
EF-DETECTION, AMPTIP FUNCTION
FOR LOW CURRENT
MEASUREMENT**

MODEL - KM 033

OPERATION MANUAL

KUSAM-MECO®

AC TRMS DIGITAL CLAMPMETER MODEL - KM 033



KUSAM-MECO®

I. SAFETY :

The meter meets UL / IEC / EN61010-1 Ed. 3.0, CAN / CSA C22.2 No. 61010-1Ed.3.0, UL/IEC/EN61010-2-032 Ed.3.0, UL/IEC/EN61010-2-033 Ed. 1.0 to measurement CAT-III 600V and CAT-IV 300V, AC & DC.

The accompanied test probe assembly meets UL/IEC/EN61010-031 Ed. 2.0 to the same meter ratings or better. IEC 61010-031 requires exposed conductive test probe tips to be $\leq 4\text{mm}$ for CAT III & CAT IV ratings. Refer to the category markings on your probe assemblies as well as on the add-on accessories (like detachable Caps or Alligator Clips), if any, for applicable rating changes.

TERMS IN THIS MANUAL :

WARNING Identifies conditions and actions that could result in serious injury or even death to the user.

CAUTION Identifies conditions and actions that could cause damage or malfunction in the instrument.









WARNING :

This manual contains information and warnings that must be followed for operating the meter safely and maintaining the meter in a safe operating condition. If the meter is used in a manner not specified by the manufacturer, the protection provided by the meter may be impaired.

Observe proper safety precautions when working with voltages above 30 Vrms, 42.4 Vpeak or 60VDC. These voltage levels pose a potential shock hazard to the user. Do not expose this product to rain or moisture. The meter is intended only for indoor use.

Keep your hands/fingers behind the hand/finger barriers (of the meter and the test leads where applicable) that indicate the limits of safe access of the hand-held part during measurement. Inspect test leads, connectors and probes for damaged insulation or exposed metal periodically. If any defects are found, replace them immediately. Only use the test lead provided with the equipment or a UL Listed Probe Assembly rated CAT III 600V or better.

INTERNATIONAL ELECTRICAL SYMBOLS :

	Caution ! Refer to the explanation in this Manual.
	Caution ! Risk of electric shock.
	Earth (Ground)
	Double Insulation or Reinforced insulation
	Fuse
	AC--Alternating Current
	DC--Direct Current
	Application around and removal from hazardous live conductors is permitted.
	Three-phase Alternating Current

BRIEF INFORMATION ON MEASUREMENT CATEGORIES

MEASUREMENT CATEGORY IV is applicable to test & measuring circuits connected at the source of the building's low-voltage MAINS installation. Examples are measurements on devices installed before the main fuse or circuit breaker in the building installation.

MEASUREMENT CATEGORY III is applicable to test & measuring circuits connected to the distribution part of the building's low-voltage MAINS installation. Examples are measurements on distribution boards (including secondary meters), circuit-breakers, Cables, bus-bars, junction boxes, switches, socket-outlets, stationary motors in the fixed installation, and equipment for industrial use.

MEASUREMENT CATEGORY II is applicable to test & measuring circuits connected directly to utilization point (socket outlets & similar points) of the low-voltage MAINS installation. Examples are measurements on MAINS CIRCUITS of household appliances, portable tools and similar equipment.

II. CENELEC Directives :

The instruments conform to CENELEC Low-voltage directive 2014/35/EU, Electromagnetic compatibility directive 2014/30/EU and RoHS directive 2015/863/EU.

III SPECIAL FEATURES :

- AmpTip™ low-current range calibrated at Jaw-tip for slim-conditions for accurate readings
- MAX / MIN Recording mode.
- MAX / MIN Crest (Peak-Hold) mode.
- Relative-zero mode.
- Display Hold
- EF-Detection (NCV).
- Back-lighted easy-to-read LCD display
- Fully Autoranging
- BeepLit™ Feature.

GENERAL SPECIFICATIONS :

- * **Sensing** : True RMS
- * **Jaws Opening size** : 26mm Max.
- * **Display** : 3-5/6 digits 6000 counts
- * **Update Rate** : 5 per second nominal
- * **Polarity** : Automatic
- * **Operating Temperature** : 0°C to 40°C
- * **Relative Humidity** : Maximum relative humidity 80% for temperature up to 31°C decreasing inearly to 50% relative humidity at 40°C.
- * **Altitude** : Operating below 2000m
- * **Storage Temperature** : -20°C ~ 60°C, <80% R.H. (with battery removed)
- * **Temperature Coefficient** : Nominal 0.1 x (specified accuracy) / °C @ (0°C — 18°C or 28°C — 40°C), or otherwise specified
- * **Power Supply** : Standard 1.5V AAA Size Battery X 2
- * **Power Consumption** : typical 14mA for current function.
- * **Low Battery** : Below approx. 2.85V for Capacitance & Hz
Below approx. 2.5V for other functions
- * **APO timing** : Idle for 32 minutes
- * **APO Consumption** : typical 5µA
- * **Dimension** : 188(L) x 66(W) x 32(H)mm
- * **Weight** : approx 202 gms.

SAFETY :

- **Safety** : Certified per IEC/UL/CSA_C22.2_# / EN standards. 61010-1 Ed.3.0, 61010-2-032 Ed. 3.0,61010-2 033 Ed. 1.0 & 61010-031 Ed. 2.0 to
Measurement Categories CAT III 600V AND CAT IV 300V AC & DC.
- **Overload Protection** :
Current via jaws : 600A DC / AC rms at <400Hz.
Voltage via terminal: 660V DC / 920VAC rms.
Other functions via terminals : 600V DC / VAC rms
- **Pollution Degree** : 2
- **E.M.C.** : Meets EN61326-1:2013
DCA and ACA Functions, in an RF field of 1V/m :
Total Accuracy = Specified Accuracy + 40 digits at around 87MHz
DCµA & Ohm Functions, in an RF field of 1V/m :
Total Accuracy = Specified Accuracy + 25 digits
Other Functions, in an RF field of 3V/m :
Total Accuracy = Specified Accuracy + 20 digits
- **Transient Protection** : 6.0kV (1.2/50µs surge)
- **Rugged Fire retarded housing.**
- **LVD EN61010-1/61010-2-032/61010-2-033 to CAT III 600V & CAT IV 300V**
- **Accessories** : Test leads set, Users Manual, Carrying case.

ELECTRICAL SPECIFICATIONS :

Accuracy is ± (% of reading digits + number of digits) or otherwise specified, at 23°C ± 5°C. Maximum Crest Factor <2 :1 at full scale & <4:1 at half scale or otherwise specified, and with frequency spectrum not exceeding the specified frequency bandwidth for non-sinusoidal waveforms.

REGULAR AC CLAMP-ON CURRENT

Range	Resolution	Accuracy ^{1) 2)}
50Hz ~ 100Hz		
600.0 A	0.1 A	±(1.5%rdg + 5dgts)
100Hz ~ 400Hz		
600.0 A	0.1 A	±(2.0%rdg + 5dgts)

¹⁾ Induced error from adjacent current-carrying conductor : < 0.6A/A

²⁾ Specified accuracy is for measurements made at the jaw center. When the conductor is not positioned at the jaw center, add 2% to specified accuracy for position errors.

CLAMP-ON AmpTip™ AC CURRENT

Range	Resolution	Accuracy ¹⁾
50Hz ~ 60Hz		
60.00 A	0.01 A	±(1.0%rdg + 5dgts)

¹⁾ Induced error from adjacent current-carrying conductor : < 0.06A/A

DCµA

Range	Resolution	Accuracy
200.0 µA	0.1 µA	±(1.0%rdg + 5dgts)
2000 µA	1 µA	

Burden Voltage : 3.5mV/µA

DC VOLTAGE

Range	Resolution	Accuracy
600.0 V	0.1 V	±(1.0%rdg + 5dgts)

Input Impedance : 10MΩ, 100pF nominal

AC VOLTAGE (with Digital Low-Pass Filter)

Range	Resolution	Accuracy
50Hz ~ 60Hz		
600.0 V	0.1 V	±(1.5%rdg + 5dgts)

Input Impedance : 10MΩ, 100pF nominal

RESISTANCE

Range	Resolution	Accuracy
600.0 Ω	0.1 Ω	±(1.0%rdg + 5dgts)
60.00KΩ	10 Ω	
600.0KΩ	100 Ω	
6000KΩ	1 kΩ	

Open Circuit Voltage : 1.0VDC typical

BeepLit™ DIODE TESTER

Range	Resolution	Accuracy ¹⁾
3.000 V	1 mV	±(1.5%rdg + 5dgts)

Test Current : 0.3mA typically

Open Circuit Voltage : < 3.5VDC typically

Short Beep Alert Threshold : Drop across 0.850V

BeepLit™ ON Threshold : <0.100V

Audible indication : Beep Sound

Visible Indication : LCD Backlight.

CAPACITANCE

Range	Resolution	Accuracy ¹⁾
200.0 μF	0.1 μF	±(2.0%rdg + 4dgts)
2500 μF	1 μF	

¹⁾ Accuracies with film capacitor or better

HZ LINE LEVEL FREQUENCY

Function	Sensitivity ¹⁾ (Sine RMS)	Range
600 V	50 V	5.00Hz~999.9Hz

Accuracy : ±(1%rdg + 5dgts)

¹⁾ DC-bias, if any, not more than 50% of Sine RMS

TEMPERATURE

Range	Accuracy ¹⁾²⁾
-40.0°C ~ 99.9°C	± (1.0% + 1.0°C)
100.0°C ~ 400°C	± (1.0% + 1°C)
-40.0°F ~ 211.8°F	± (1.0% + 2.0°F)
212°F ~ 752°F	± (1.0% + 2°F)

¹⁾ Accuracies assume meter interior has the same temperature of the ambient (isothermal stage) for a correct junction voltage compensation. Allow the meter & the type-K probe set to reach isothermal stage for a significant change of ambient temperature. It can take up to an hour for changes >5°C.

²⁾ Type-K thermocouple range & accuracy not included.

CREST (Peak-Hold)

Applicability	Voltage & Non-invasion Current functions
Accuracy	Add ± 250 digits to specified accuracy for changes > 5ms in duration.

BeepLit™ CONTINUITY TESTER

Continuity Threshold	Between 30Ω & 480Ω
Continuity ON Response Time	15ms approx.
Audible Indication	Beep sound
Visible Indication	LCD Backlight

NON-CONTACT EF-DETECTION

Bar-Graph Indication	EF-H (Hi Sensitivity)	EF-L (Lo Sensitivity)
	Typical Voltage (Tolerance)	
-	10V (2V~20V)	40V (10V~70V)
--	20V (4V~40V)	80V (20V~140V)
---	40V (8V~70V)	160V (40V~280V)
----	80V (16V~140V)	320V (80V~560V)
-----	160V (>40V)	500V (>160V)

Indication : Bar-graph segments & audible beep tones proportional to the field strength.

Detection Frequency : 50/60Hz

Detection Antenna : Inside the top side of the stationary jaw

Probe-Contact EF-Detection : For more precise indication of live wires, such as distinguishing between live and ground connections, use one single probe to test via terminal COM for direct Metal Probe-contact EF-Detection to achieve the most distinctive indication.

VI. PRODUCT DESCRIPTION :

This manual uses only representative model(s) for illustrations. Please refer specification details for function availability to this model.

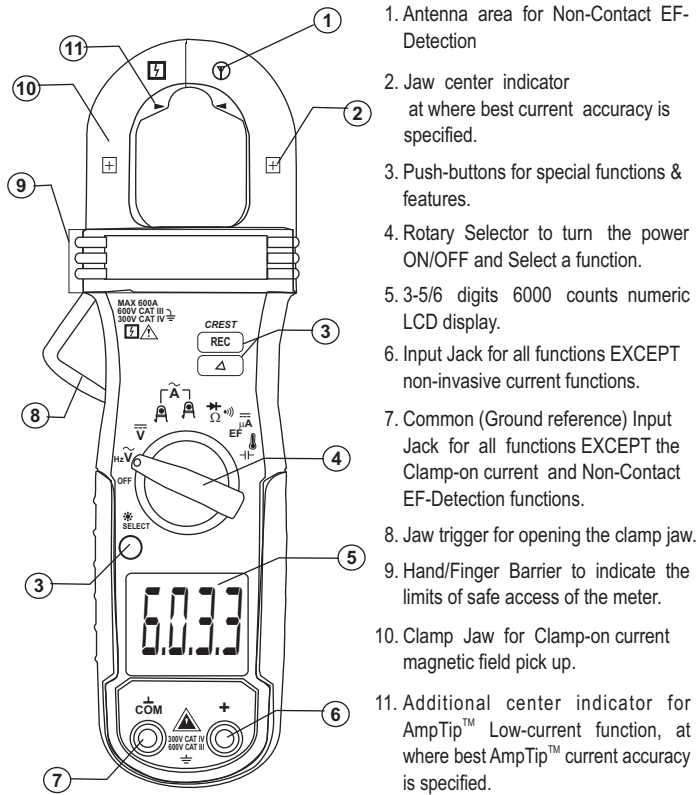

VII. OPERATION :

WARNING : Before and after hazardous voltage measurements, test the voltage function on a known source such as line voltage to determine proper meter functioning.

ACV, Line-level Hz :

Inputs, are made through the test lead terminals **COM/+**. Defaults at **ACV** Function. Press **SELECT** button momentarily to select **Line-level Hz** function.

Note : **ACV** and **Line-level Hz** function are equipped with low-pass filter, & are capable of dealing with **VFD** (Variable Frequency Drive) signals. It also improves ACV reading stability in noisy electrical environments.

DCV

Inputs are made through the test lead terminals **COM/+**.

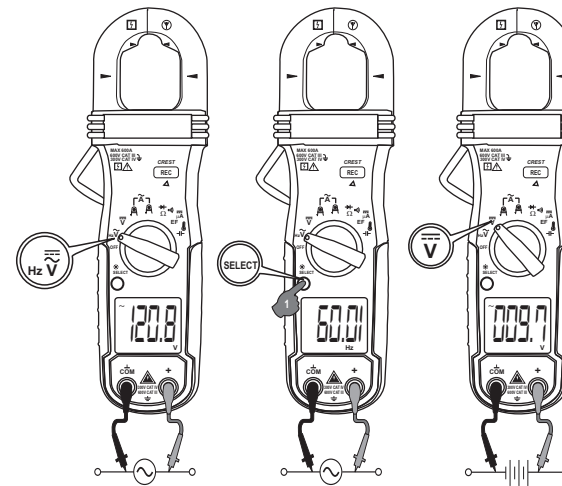

Clamp-on Current Measurements :**Application & Removal of the Jaws**

Press the jaw trigger & clamp the jaws around conductor(s) of only one single pole of a circuit for load current measurements. Make sure the jaws are completely closed, or else it will introduce measurement errors. Enclosing conductors of more than one pole of a circuit may result in differential current (like identifying leakage current) measurements. Align the conductors to the Jaws center indicators (Regular or AmpTip™ indicators where applicable) as much as possible to get the best measuring accuracy. For removal, press the jaw trigger and remove the jaws from the conductors.

Adjacent current-carrying devices such as transformers, motors and conductor wires may affect measurement accuracy. Keep the jaws away from them as much as possible to minimize influence.

WARNING :

This Clamp-on meter series is designed to directly apply around or remove from uninsulated hazardous live conductors. But still, individual protective equipment must be used if hazardous live parts in the installation where measurement is to be carried out could be accessible. Do not use the meter to measure currents above the rated frequency (400Hz). Circulating currents may cause the magnetic circuits of the Jaws reach a hazardous temperature.

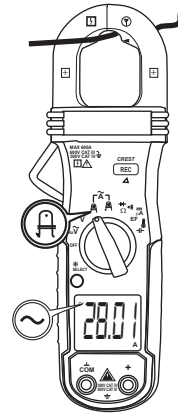
Clamp-on AmpTip™ ACA

Input is made via the clamp jaws where best accuracy is specified near the jaw TIP-CENTER area for low-current measurements of thin conductors. Defaults at **ACA** function.

Press **SELECT** button momentarily to select **DCA** function.

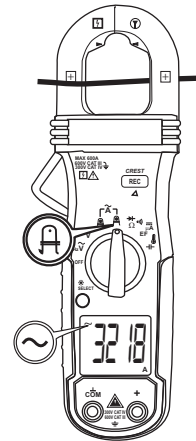
Clamp-on Regular ACA

Input is made via the clamp jaws where best accuracy is specified at the jaw CENTER area. Defaults at **ACA** function.

Press **SELECT** button momentarily to select **DCA** function.

Ω Resistance, *))) BeepLit™ Continuity & ➔ BeepLit™ Diode :

Inputs are made through the test lead terminals **COM/+**. Defaults at **Ω Resistance**. Press **SELECT** button momentarily to select the subject functions in sequence.

***))) BeepLit™ Continuity :**

This function is having improved convenience for checking wiring connections and operation of switches. Resistance threshold is being used. A continuous beep tone together with flashing display backlight indicate a complete wire. Such audible and visible indications improve continuity readabilities in noisy working environments.

➔ BeepLit™ Diode :

Reading indication : Forward voltage drop (forward biased) for a good silicon diode is between 0.400V to 0.900V. A higher reading indicates a leaky diode (defective). A zero reading indicates a shorted diode (defective). An over-range display indicates an open diode (defective) Reverse the test leads connections (reverse biased) across the diode. The digital display shows over-range if the diode is good. Any other readings indicate the diode is resistive or shorted (defective).

Beep-Alert & BeepLit™ Indication :

When the display reading drops across 0.850V, the meter alerts a short beep to signal a reasonable forward voltage drop of common diodes. However, if the reading further drops below 0.100V, the meter gives a continuous beep tone together with flashing display backlight to indicate a shorted diode or a complete wire. it is similar to that of **BeepLit™ Continuity** function but **BeepLit™ Diode**, instead, is based on voltage threshold to indicate a complete wire.

CAUTION :

Using **Resistance, BeepLit™ Continuity** or **BeepLit™ Diode** function in a live circuit will produce false results and may damage the meter. In many cases, the suspected components must be disconnected from the circuit to obtain an accurate measurement reading.

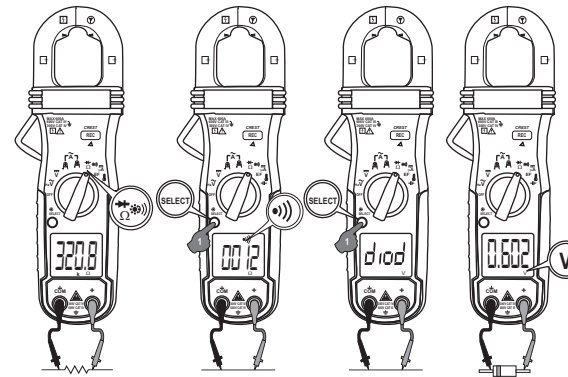

EF-Detection of Electric Field

Defaults at high sensitivity **EF-H**. The meter displays "**EF-H**" when it is ready. If it is too sensitive for your applications, press **SELECT** button momentarily to select lower sensitivity "**EF-L**". The detected Electric Field strength is indicated as a series of bar-graph segments on the display plus variable beep tones.

Non-Contact EF-Detection (NCV) : An antenna is located along the top-right end of the stationary clamp jaw, which detects electric field that surrounds energized conductors. It is ideal for tracing live wiring connections, locating wiring breakage and to distinguish between live or earth connections.

Probe-Contact EF-Detection : For more precise indication of live wires, such as distinguishing between Live and Ground connections, use one single probe to test via terminal **COM** for direct metal Probe-Contact EF-Detection to achieve the most distinctive indication.

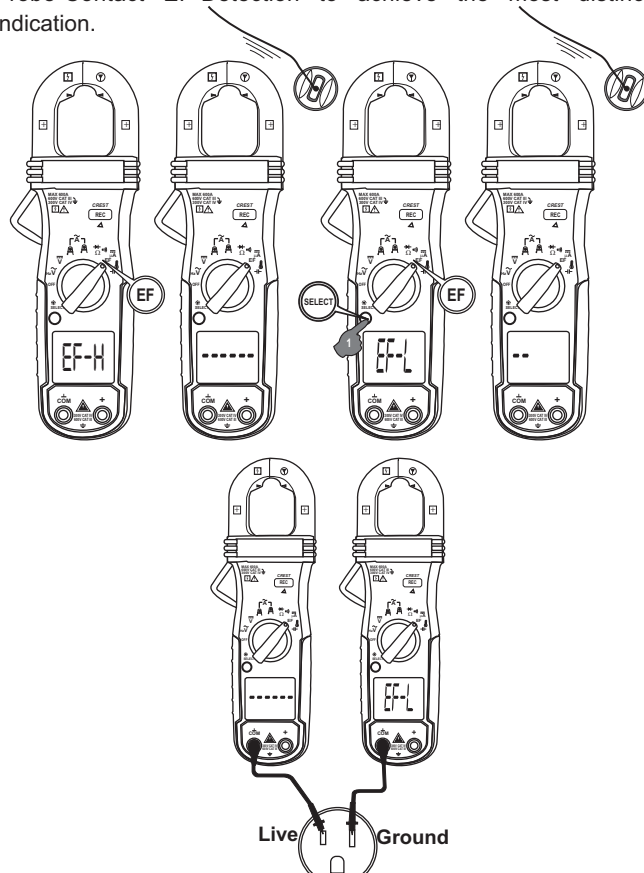

DC μ A Current function :

Inputs are made through the test lead terminals **COM/+**. Defaults at **EF-Detection** function. Press **SELECT** button momentarily two times to select **DC μ A** function.

Application Notes :

The **DC μ A** function designed especially for HVAC/R flame sensor applications. The 0.1 μ A resolution is useful for identifying the minute current changes in flame detector applications. Flame signal current check should indicate steady flame signal of at least 2 μ A for a rectification type, or 1.5 μ A for an ultra-violet type (8 μ A for self checking systems). If a flame signal current with inadequate strength or fluctuation beyond 10%, check the following to avoid the risk of unwanted flame relay dropout :

For gas or oil flames (Minipeeper) :

- ❖ Low supply voltage
- ❖ Detector location
- ❖ Defective detector wiring
- ❖ Faulty Minipeeper
- ❖ Dirty viewing windows

For oil flames (Photocell) :

- ❖ Detector location & wiring
- ❖ Smoky flame or poorly adjusted air shutter
- ❖ Faulty Photocell
- ❖ Temperature over 165°F (74°C) at photocell

For gas flames (Flame Rod) :

- ❖ Ignition interference (A flame signal current difference with the ignition both on and off greater than 0.5 μ A indicates the presence of ignition interference).
- ❖ Insufficient ground (must be at least 4 times the detector area).
- ❖ Flame lifting off burner head (ground), or not continuously in contact with the flame rod.
- ❖ Temperature in excess of 600°F (316°C) at the flame electrode insulator causing short to ground.

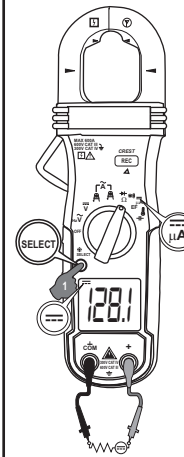

± Capacitance & Temperature :

Inputs are made through the test lead terminals **COM/±**. Defaults at **± Capacitance**. Press **SELECT** button momentarily to select °C (Celsius) and °F (Fahrenheit) in sequence (°F selection can be left out as factory calibration default for countries that only accept metric units).

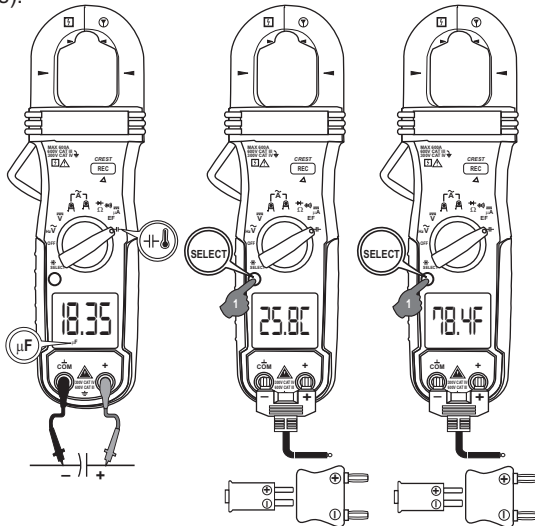

Note :

Be sure to insert the banana plug type-K temperature bead probe Bkp60 with correct **±** polarities. Banana pins to type-K socket adapter Bkb32 (Optional purchase) can be used to accept other type-K probes using standard miniature plug.

Temperature accuracies assume meter interior has the same temperature of the ambient (isothermal stage) for a correct junction voltage compensation. Allow the meter and the type-K probe set to reach isothermal stage for a significant change of ambient temperature. It can take up to an hour for changes > 5°C.

CAUTION :

Discharge capacitors before making capacitance measurements. Large value capacitors should be discharged through an appropriate resistance load. Using capacitance function in a live circuit will produce false results and may damage the meter. In many cases the suspected components must be disconnected from the circuit to obtain accurate measurement readings.

HOLD :

Hold feature freezes the display for later view. LCD **H** turns on. Press the **HOLD** button momentarily to toggle the hold feature.

RECORD MODE :

Press **REC** button momentarily to activate **MAX/MIN** recording mode. LCD **MAX & MIN** turn on. The meter beeps when new **MAX** (maximum) or **MIN** (minimum) reading is updated. Press the button momentarily to read the **MAX**, **MIN** and **MAXMIN** (active measurement) readings in sequence. Press the button for 1 second or more to exit this mode. Auto-Power-Off is disabled automatically in this mode.

5ms CREST MODE :

Press **CREST** button for one second or more to activate **CREST** mode (instantaneous **PEAK-HOLD**) to capture current or voltage peak values in duration as short as 5ms. LCD **C** & **MAX** turn on. The meter beeps when new **C****MAX** (maximum) or **C****MIN** (minimum) reading is updated. Press the button momentarily to toggle the **C****MAX** and **C****MIN** readings. Press the button for 1 second or more to exit this mode. Auto-power-Off is disabled automatically in this mode.

LCD Backlight & Auto-Backlight-Off (ABO) :

Press the **SELECT** button for 1 second or more to toggle the LCD backlight. The **ABO** mode turn the LCD backlight off automatically after idling for 10 minutes to extend battery life. See **Power-on Options** section for disabling **ABO**.

Intelligent Auto-Power-Off (APO) :

The Auto-Power-Off (APO) mode turns the meter off automatically to extend battery life after approximately 32 minutes of no specified activities, where applicable, below :

1. Rotary switch or push button operations.
2. Significant measuring readings of above 8.5% of ranges.
3. Non-over-range readings for Resistance, Continuity or Diode function.
4. Non-zero readings for Hz function.

In other words, the meter will intelligently reset the APO mode when it is under normal measurements. To wake up the meter from APO, press the **SELECT** button momentarily and release, or turn the rotary switch OFF and then back on. Always turn the rotary switch to the OFF position when the meter is not in use.

POWER-ON OPTION :**Disabling APO & ABO**

Press & hold the **SELECT** button while powering on the meter can disable both **APO & ABO** features temporarily during the power on session. The LCD will display “**dAPO**” to confirm selection before the **SELECT** button is released.

Shortening APO idling time for inspection

Press & hold the **HOLD** button while powering on the meter can shorten the **APO** idling time to 5 seconds temporarily during the power on session. It is designed mainly for production inspection.

Showing all LCD segments for inspection

Press & hold the **REC** button while powering on the meter can hold & show all LCD segments before the button is released. It is designed mainly for production inspection.

V. MAINTENANCE :**WARNING :**

To avoid electrical shock, disconnect the meter from any circuit, remove the test leads from the input jacks and turn OFF the meter before opening the case. Do not operate with open case.

Trouble Shooting :

If the instrument fails to operate, check batteries and test leads etc., and replace as necessary. Double check operating procedure as described in this manual.

Cleaning and Storage :

Periodically wipe the meter & the test probe assembly with a damp cloth and mild detergent. Do not use abrasives or solvents. Allow to dry completely before operating. If the meter is not to be used for periods of longer than 60 days, remove the batteries and store them separately.

Battery replacement :

The meter uses standard 1.5V AAA Size (IEC R03) battery X 2. Loosen the 2 captive screws from the battery cover case. Lift the battery cover case. Replace the batteries. Replace battery cover case. Re-fasten the screws.

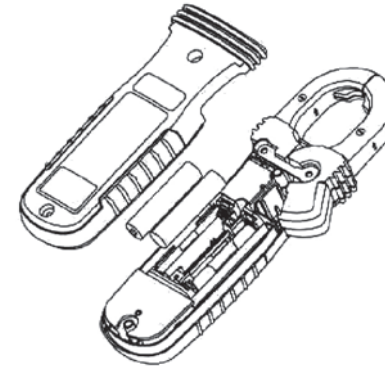

MUMBAI

TEST CERTIFICATE
AC TRMS DIGITAL CLAMPMETER

This Test Certificate warrants that the product has been inspected and tested in accordance with the published specifications.

The instrument has been calibrated by using equipment which has already been calibrated to standards traceable to national standards.

MODEL NO. **KM 033**

SERIAL NO. _____

DATE: _____

ISO 9001
REGISTERED



WARRANTY

Each "KUSAM-MECO" product is warranted to be free from defects in material and workmanship under normal use & service. The warranty period is one year (12 months) and begins from the date of despatch of goods. In case any defect occurs in functioning of the instrument, under proper use, within the warranty period, the same will be rectified by us free of charges, provided the to and fro freight charges are borne by you.

This warranty extends only to the original buyer or end-user customer of a "KUSAM-MECO" authorized dealer.

This warranty does not apply for damaged Ic's, fuses, burnt PCB's, disposable batteries, carrying case, test leads, or to any product which in "KUSAM-MECO's" opinion, has been misused, altered, neglected, contaminated or damaged by accident or abnormal conditions of operation or handling.

"KUSAM-MECO" authorized dealer shall extend this warranty on new and unused products to end-user customers only but have no authority to extend a greater or different warranty on behalf of "KUSAM-MECO". "KUSAM-MECO's" warranty obligation is limited, at option, free of charge repair, or replacement of a defective product which is returned to a "KUSAM-MECO" authorized service center within the warranty period.

THIS WARRANTY IS BUYER'S SOLE AND EXCLUSIVE REMEDY AND IS IN LIEU OF ALL OTHER WARRANTIES, EXPRESS OR IMPLIED, INCLUDING BUT NOT LIMITED TO ANY IMPLIED WARRANTY OF MERCHANTABILITY OR FITNESS FOR A PARTICULAR PURPOSE. "KUSAM-MECO" SHALL NOT BE LIABLE FOR ANY SPECIAL, INDIRECT, INCIDENTAL OR CONSEQUENTIAL DAMAGES OR LOSSES, INCLUDING LOSS OF DATA, ARISING FROM ANY CAUSE WHATSOEVER.

All transaction are subject to Mumbai Jurisdiction.